

ER - -
kg mm

IP

PCB C



/SPECIFICATIONS

	ER - -		~
			RH %
			. m/s ² . G
	kg	J	N·m
	± . mm	J	. kg·m ²
	kg	J	%/sec
	mm	J	%/sec
	IP	J	%/sec
	IP / IP	J	+ %/- °
	AC	J	+ %/- °
		J	± °

/OPERATING SPACE

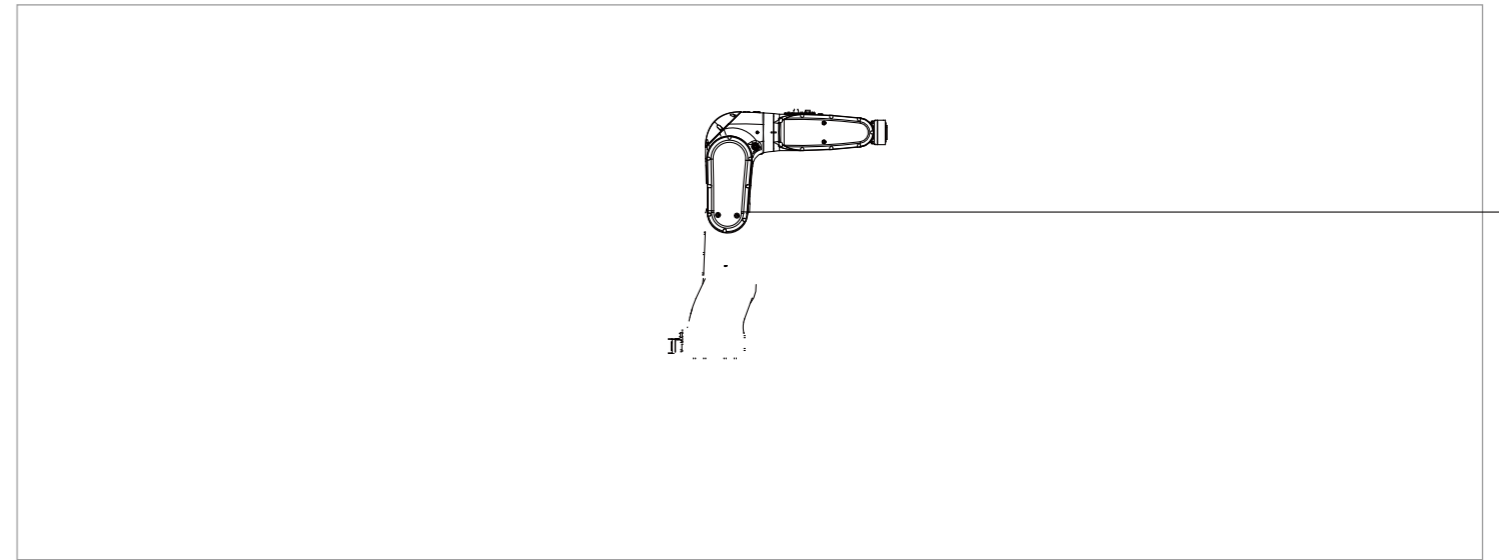

/BASE MOUNTING SIZE

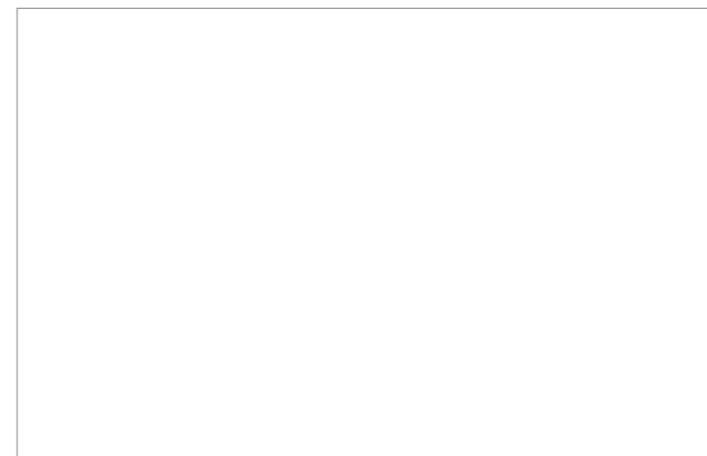

/END FLANGE MOUNTING SIZE

